

Bey★nd

ENERGY SERVICES & TECHNOLOGY CORP.



MERCURY MPD™

Professional MPD Solutions
at Low Operating Costs

FOR USE IN OFFSHORE AND LAND APPLICATIONS



Front entry

Bey★nd



Interactive Tour



MERCURY

MERCURY MPD™

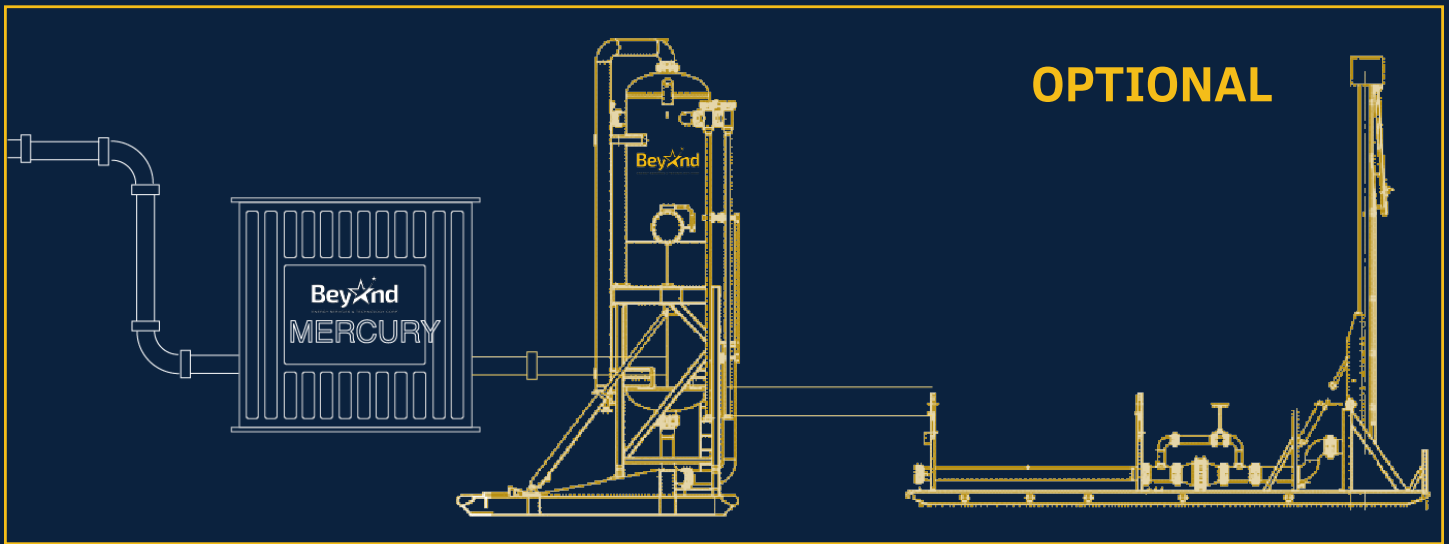

Functionality

- Entry-level LOW operating expense MPD system
- Traps and holds pressure on the wellbore
- Minimal footprint on site
- Efficient Integration into the rig system
- Available as a stand-alone skid or container
- Applicable to manned or unmanned operations
- Uses the same automated software as Beyond Energy's full NITRO MPD™ system
- Eliminates nuisance gas and associated downtime
- Fastest in industry rig up and rig down time
- Minimal rig intrusion
- PRV equipped to protect the wellbore and equipment

Includes

- Single-line 5k psi choke manifold system
- B.E.S.T. TITAN series RCD with accessories
- RCD pneumatic valve package
- High-pressure pipe/hose package
- Automated choke valve
- B.E.S.T. control system (hydraulic or electric)
- Pressure Relief Valve (PRV)

Optional Equipment

- B.E.S.T. integrated gas buster
- Gas flow meter
- B.E.S.T. flare stack
- Coriolis flow meter

Container dimensions: 2.74 m L x 2.19 m W x 2.59 m H / 9' L x 7'2" W x 8'5" H



Total gross weight: 3,120 kg / 6,878 lbs



Advantages of the Beyond MPD System

Fewer loads to transport

Our complete, small footprint MPD package requires only 1 load vs. 5-6 loads for packages available in the market today.

Faster & less Expensive rig up & Rig down

Our integrated package requires less piping and with our drop off container, rig up and rig down times are substantially reduced.

Required Crew onsite

The MERCURY MPD™ package is suitable for both manned and unmanned operations.

24/7 Engineering Support

With the best Engineering Team in the business, our staff assist you with designing your wells, supporting the field operations 24/7, monitoring all drilling activities while ensuring the technical integrity of the drilling operations.

Experienced & Motivated team

The most experienced and motivated team of Operators and Supervisors. All of our senior supervisors have 20+ years of experience in MPD and UBD applications worldwide, ensuring your well is in the best hands possible.

Experience

We have drilled over 2,000 wells in the last 7 years, under various conditions, for several clients globally, ranging from multiphase operations to HPHT wells with no practical drilling window.



Electric choke & High-pressure relief valves



Interactive Tour



We do **Managed Pressure Drilling**.

